

MODEL

**AFG** Oil  
Burner

# Instruction Manual

**Types "F" & "M" air tubes**

Motor voltage: 120 Vac / 60 Hz



AFG burner with type "F" air tube

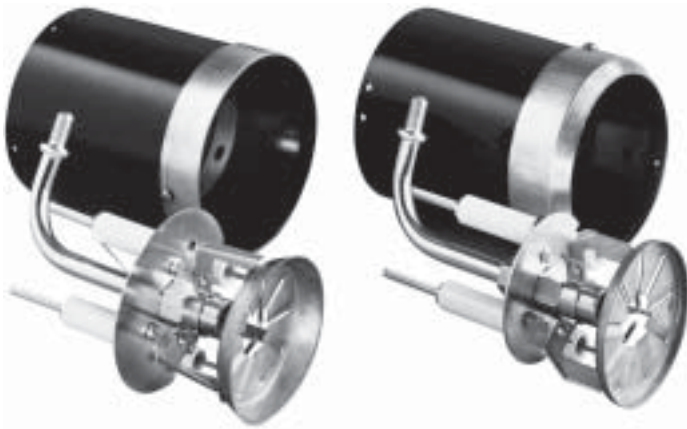

Type "L1" head

Type "V1" head

Type "M" air tube combinations

*Beckett*

## Contents

### Prepare before installing

Verify specifications .....	3
Be aware of hazard definitions .....	3
Check certifications/approvals .....	3
Notice special requirements .....	3

### Prepare burner & site

Inspect/prepare installation site .....	4
Prepare burner .....	5
Check/adjust “Z” dimension .....	6
Set head position adjusting plate (“V1” head only) .....	7

### Adjust, pipe & wire burner

Mount burner on appliance .....	8
Connect fuel lines .....	8
Wire burner .....	8

### Startup & adjust burner

Startup burner/set combustion .....	10
Set combustion with instruments .....	10

### Service & maintain burner

Perform annual maintenance .....	10
To replace the blower wheel .....	10
Replacement parts .....	11
Owner’s information and warranty .....	12

**Table 1** — Air tube combination (ATC) codes\*

Firing rate (GPH)	Head	Static plate size (inches)	Venturi	ATC codes for usable air tube lengths: (“A” in inches, see Figure 2, page 6)									
				4 1/2	5	5 3/8	6 5/8	7	7 1/4	9	10 1/2	13	16
0.40-0.75	F0	3 3/8 U	None	AF44XR	-	AF53XR	AF65XR	-	AF72XR	AF90XR	AF104XR	AF130XR	AF160XR
0.75-1.25	F3	2 3/4	None	AF44XN	-	AF53XN	AF65XN	-	AF72XN	AF90XN	AF104XN	AF130XN	AF160XN
0.85-1.35	F4	2 3/4	None	AF44WH	-	AF53WH	AF65WH	-	AF72WH	AF90WH	AF104WH	AF130WH	AF160WH
0.85-1.65	F6	2 3/4	None	AF44YB	-	AF53YB	AF65YB	-	AF72YB	AF90YB	AF104YB	AF130YB	AF160YB
1.10-2.00	F12	2 3/4	None	AF44XO	-	AF53XO	AF65XO	-	AF72XO	AF90XO	AF104XO	AF130XO	AF160XO
1.65-2.50	F22	2 3/4	None	AF44XP	-	AF53XP	AF65XP	-	AF72XP	AF90XP	AF104XP	AF130XP	AF160XP
2.50-3.00	F31	None	None	AF44XS	-	AF53XS	AF65XS	-	AF72XS	AF90XS	AF104XS	AF130XS	AF160XS
0.50-1.00	L1	3 3/8 U	8 holes	-	AFG50MB	-	-	AFG70MB	-	AFG90MB	-	-	-
0.75-2.75	V1	2 3/4	8 holes	-	AFG50MD	-	-	AFG70MD	-	AFG90MD	-	-	-

\* Refer to Beckett OEM Specification Guide, Part No. 6711, for non-standard air tube combinations

## Prepare before installing

### Verify specifications

<b>Capacity</b>	"F" heads Firing rate..... 0.40 – 3.00 GPH Input..... 56,000 – 420,000 Btuh
	"L1" head Firing Rate ..... 0.40 – 1.10 GPH Input..... 56,000 – 154,000 Btuh
	"V1" head Firing Rate ..... 0.75 – 2.75 GPH Input..... 105,000 – 385,000 Btuh
<b>Fuels</b>	<b>U. S.</b> ..... No. 1 or No. 2 heating oil only (ASTM D396) <b>Canada</b> ..... No. 1 stove oil or No. 2 furnace oil only
<b>Electrical</b>	Power supply ..... 120 VAC/60 HZ/single phase Operating load ..... 5.8 AMPS maximum Motor ..... 1/7 HP, 3450 RPM, NEMA 48M frame ..... rotation CCW when facing shaft end Ignition ..... Continuous-duty iron-core transformer OR ..... Continuous-duty solid state igniter
<b>Fuel unit</b>	Outlet pressure ..... Note 1
<b>Air tube</b>	ATC code ..... See Table 1, page 2
<b>Dimensions</b>	Height (maximum)..... 11 1/2 inches
	Width (maximum)..... 12 7/8 inches
	Depth (chassis only) ..... 6 9/16 inches
	Air tube diameter ..... 4 inches
Note 1: See appliance manufacturer's burner specifications for recommended outlet pressure. Pressure is 100 psig unless otherwise noted.	

### Be aware of hazard definitions

- DANGER** Denotes presence of a hazard which, if ignored, will result in severe personal injury, death or substantial property damage.
- WARNING** Denotes presence of a hazard which, if ignored, could result in severe personal injury, death or substantial property damage.
- CAUTION** Denotes presence of a hazard which, if ignored, could result in minor personal injury or property damage.
- NOTICE** Intended to bring special attention to information, but not related to personal injury or property damage.

### Check certifications/approvals

- Underwriters Laboratories has certified this burner to comply with ANSI/UL 296 and has listed it for use with #1 or #2 fuel oil as specified in ASTM D396. *Low sulfur #1 and #2 fuel oils reduce heat exchanger deposits with all burners compared to the standard fuels. Reduced deposits extend the service interval for cleaning and improve the efficiency of the appliance over time. Low sulfur fuels reduce particulate and oxides of nitrogen emissions as well. The Oilheat Manufacturers' Association recommends these fuels as the preferred fuels for this burner.*
- State and local approvals are shown on burner rating label (see below).
- All oil burners should be installed in accordance with regulations of the latest revision of the National Fire Protection Association Standard NFPA 31 and in complete accordance with all local codes and authorities having jurisdiction. Regulation of these authorities take precedence over the general instructions provided in this installation manual.
- For recommended installation practice in Canada, reference to CSA Standard B139-M91.

### Notice special requirements

- DANGER** This equipment must be installed, adjusted and started only by a qualified service agency – an individual or agency, licensed and experienced with all codes and ordinances, who is responsible for the installation and adjustment of the equipment. The installation must comply with all local codes and ordinances and with the latest revision of the National Fire Protection Standard for Oil-Burning Equipment, NFPA 31 (or CSA B139-M91).
- WARNING** Read all instructions before proceeding. Follow all instructions completely. Failure to follow these instructions could result in equipment malfunction, causing severe personal injury, death or substantial property damage.
- NOTICE** **Concealed damage** — If you discover damage to the burner or controls during unpacking, notify the carrier at once and file the appropriate claim.
- NOTICE** When contacting Beckett for service information — Please record the **burner serial number** (and have available when calling or writing). You will find the serial number on the Underwriters Laboratories label, located on the left rear of the burner, or the cover mounting plate. See illustration below.

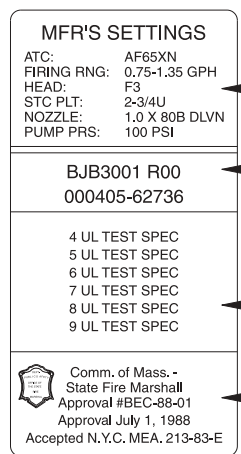
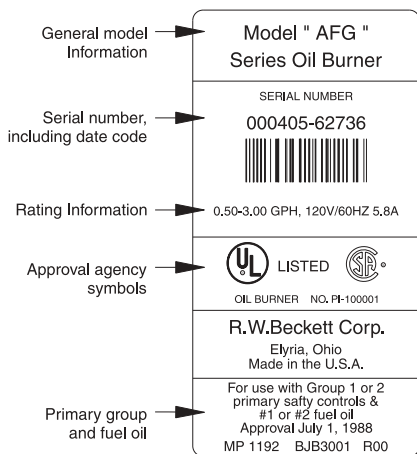

- ← R.W. Beckett manufacturer's settings
- ← R.W. Beckett specification number and revision
- ← Can be customized by individual specification
- ← State and local approvals

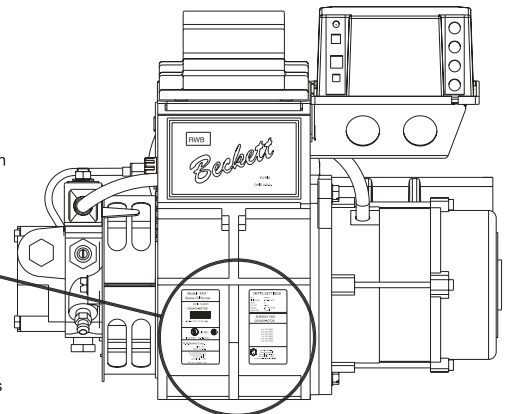

## Prepare burner & site

### Inspect/prepare installation site

#### Chimney or vent

- Inspect the chimney or vent, making sure it is properly sized and in good condition for use.
- For those installations not requiring a chimney, such as through-the-wall vented appliances, follow the instructions given by the appliance and power venter (if used) manufacturers.

#### Direct air supply and sidewall venting

- Some AFG burners are equipped with combustion air boots to allow use of outside air for combustion.
- When sidewall venting appliances, carefully follow appliance and power venter instructions for installation and wiring.

#### Combustion air supply

See NFPA Standard 31 for complete details.

**WARNING** If the burner is not supplied with a reliable combustion air source, the burner cannot properly burn the fuel. This would result in incomplete combustion, causing sooting and possible emission of carbon monoxide. Severe personal injury, death or substantial property damage could occur.

#### Appliance located in confined space

The confined space should have two (2) permanent openings: one near the top of the enclosure and one near the bottom of the enclosure. Each opening shall have a free area of not less than (1) one square inch per 1,000 BTU's per hour of the total input rating of all appliances within the enclosure. The openings shall have free access to the building interior, which should have adequate infiltration from the outside.

#### Exhaust fans and other air-using devices

Size air openings large enough to allow for all air-using devices in addition to the minimum area required for combustion air. If there is any possibility of the equipment room developing negative pressure (because of exhaust fans or clothes dryers, for example), either pipe combustion air directly to the burner or provide a sealed enclosure for the burner and supply it with its own combustion air supply.

#### Outside air kit applications

Refer to separate instruction sheet supplied with AFG outside air kit for installation. This optional kit allows combustion air to be piped directly to the burner. (Part number 51747.)

**WARNING** You must install the outside air kit strictly following the kit installation instructions. Do not attempt to install outside air piping without using the AFG outside air kit and instructions. Failure to do so could result in burner or heating appliance failure, causing potential severe personal injury, death or substantial property damage.

### Inspect/prepare installation site *(continued)*

#### Clearances to burner and appliance

- Provide space around burner and appliance for easy service and maintenance.
- Check minimum clearances against those shown by the appliance manufacturer and by applicable building codes.

#### Combustion chamber — Burner retrofitting

Verify that the appliance combustion chamber provides at least the minimum dimensions given in Table 2.

**CAUTION** When retrofitting an appliance that has a stainless steel chamber — A chamber burnout could result from the use of a high performance burner. Protect the chamber from high temperatures through the use of "wet-pac" or a similar ceramic liner. Some new equipment may contain stainless steel chambers that have been designed and tested by the manufacturer for use with flame retention burners — ceramic protection would not be necessary. Refer to appliance manufacturer's instructions. Failure to comply could result in damage to heating equipment.

**Table 2** — Minimum combustion chamber dimensions

Chamber dimension (inches)					
Firing rate (GPH)	Round I.D.	Rectangular		Height	Floor to nozzle
		Width	Length		
0.50	8	7	8	12	5-6
0.75	9	8	9	12	5-6
1.00	10	9	10	12 ½	5-6
1.25	11	10	11	12 ½	5-6
1.50	12	11	12	13	6-7
2.00	14	12	15	13 ½	6-7
2.50	16	13	17	14	7-8
3.00	18	14	18	15	7-8

## Prepare burner & site

### Prepare burner

#### Low firing rate baffle

- The AFG Low Firing Rate Baffle (LFRB), item 7, page 11, reduces the air flow (cfm). The LFRB is sometimes used for firing rates under 1.00 GPH as listed in the table below. Refer to the appliance manufacturer's instructions or the Beckett *OEM Specification Guide* part number 6711. Do not omit the LFRB when specified. Omitting the baffle when specified or installing the baffle when not specified could result in poor burner performance.

Burner head type	Low Firing Rate Baffle if specified:
F0	up to 0.65 GPH
F3 or L1	up to 0.85 GPH
F4 or F6	up to 0.90 GPH
V1	up to 1.00 GPH

#### Burner fuel unit

- Verify that the burner fuel unit is compatible with the oil supply system. For more details, refer to "Connect Fuel Lines" on page 8.

#### Attach air tube (if not already installed)

If using a flange and gasket, slide them onto the air tube. Then attach the air tube to the burner chassis using the four sheet metal screws provided. See Figure 2 on page 6 for details.

#### Install burner nozzle (if not already installed)

**WARNING** Make certain the nozzle is selected for the fuel unit pressure used. For applications with fuel unit pressure above 100 psig, the nozzle rated capacity will be less than the appliance firing rate. Use only the specified spray pattern unless combustion test results indicate the need for a change. Failure to use the correct nozzle size and type can result in unacceptable combustion, possibly causing severe personal injury, death or substantial property damage.

- Remove the plastic plug protecting the nozzle adapter threads.
- Place a  $\frac{3}{4}$ " open-end wrench on the nozzle adapter. Insert the nozzle into the adapter and finger tighten. Finish tightening with a  $\frac{5}{8}$ " open-end wrench. Use care to avoid bending the burner head support legs or electrodes. See CAUTION, above right.
- If you remove the head to replace the nozzle (type "L1" or "V1" heads), carefully reconnect the head to the nozzle adapter, making sure to butt the head support to the nozzle adapter shoulder (see Figures 3 and 4, page 7).

If the nozzle is already installed, remove the nozzle line assembly to verify that the nozzle size and spray pattern are correct for the application (per appliance manufacturer's information or Beckett *OEM Specification Guide*, part number 6711. Verify that the electrode tip settings comply with Figure 1.

If the nozzle is not installed, obtain a nozzle of the manufacturer, capacity and spray angle specified in appliance manufacturer's information or Beckett *OEM Specification Guide*, part number 6711. For conversions or upgrades, when information is not available for the application:

- Refer to table below to select the mid-range nozzle spray angle for the head type being used.
- Fire the burner and make sure the combustion is acceptable and the flame is not impinging on chamber surfaces.
- If a shorter flame is needed, select a wider spray angle. If a longer flame is needed, select a narrower spray angle.
- Either hollow or solid spray patterns may be used. If combustion results are not satisfactory with the selected spray pattern, try the other pattern.

Recommended nozzle spray angles	
"F" head	60°, 70° or 80° nozzle
"L1" head	45°, 60° or 70° nozzle
"V1" head	45°, 60° or 70° nozzle

### Prepare burner (continued)

#### Install burner nozzle (if not already installed) (continued)

**CAUTION** Use care when removing and installing oil nozzles:

- Inspect the nozzle adapter before installing nozzle. If it is grooved or scratched on the sealing surface, replace the nozzle line assembly. Otherwise, oil could leak at the nozzle-adapter joint, causing serious combustion problems.
- Protect the nozzle orifice and strainer when installing. If the orifice gets dirt in it or is scratched, the nozzle will not function properly.
- Do not over-torque the nozzle when installing. This will cause deep grooves in the nozzle adapter, preventing a seal when a new nozzle is installed.
- Use a wrench or vise to hold the nozzle adapter. DO NOT attempt to remove or replace nozzle without holding adapter. The nozzle alignment could be seriously damaged. Use a nozzle wrench that secures the adapter or use  $\frac{3}{4}$ " and  $\frac{5}{8}$ " open-end wrenches.
- Do not squeeze the electrodes too tightly when handling the nozzle line assembly. This could change the electrode tip settings or damage the ceramic electrode insulators.
- Carefully check and realign electrode tips after replacing nozzle, ensuring the electrode settings comply with Figure 1.

#### Check/adjust electrodes

Check the electrode tip settings. Adjust if necessary to comply with the dimensions shown in Figure 1. To adjust, loosen the electrode clamp screw and slide/rotate electrodes as necessary. Securely tighten the clamp screw when finished.

Figure 1 — Electrode settings

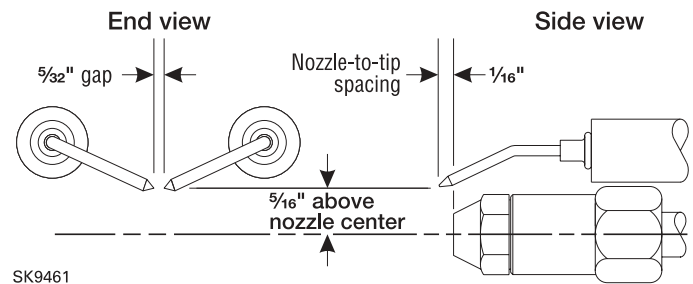

#### Servicing nozzle line assembly

- Turn off power to burner before proceeding.
- Disconnect oil connector tube from nozzle line.
- Loosen the two screws securing igniter retaining clips and rotate both clips to release igniter baseplate. Then tilt igniter back on its hinge.
- Remove splined nut.
- "F" head air tubes  
Remove nozzle line assembly from burner, being careful not to damage the electrodes or insulators while handling. To ease removal of long assemblies (over 9 inches), rotate assembly 180° from installed position after pulling partially out of tube.
- "L1" and "V1" head air tubes  
Slide nozzle line assembly forward (further into air tube) so the head clears the venturi opening. Then rotate the nozzle line assembly 90° so the nozzle line end points up. Pull the nozzle line assembly toward you and remove assembly from burner.
- To replace the nozzle assembly, reverse the above steps.

## Prepare burner & site

### Check/adjust "Z" dimension - "F" head

Figure 2 — "F" heads (plus burner detail for all head styles) (see Table 3 for dimensions)

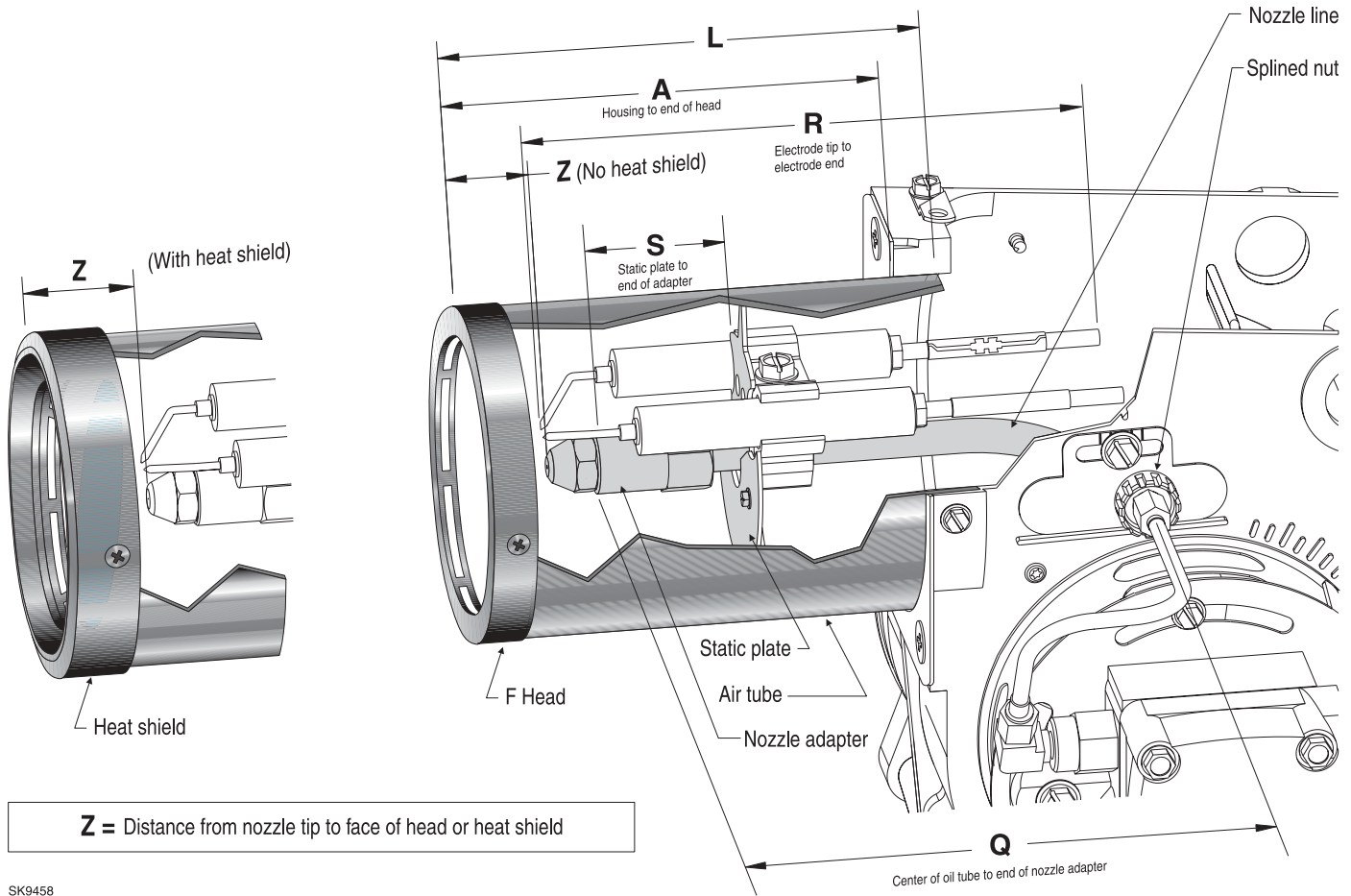

SK9458

- See Figure 2 above. The important "Z" dimension is the distance from the face of the nozzle to the flat face of the head (or heat shield, if applicable). This distance for **F heads** is 1 1/8" (1 3/8" if the air tube has a heat shield). The "Z" dimension is factory set for burners shipped with the air tube installed. Even if factory set, verify that the "Z" dimension has not been changed.
- Use the following procedure to adjust the "Z" dimension, if it is not correct:
  - Turn off power to the burner.
  - Disconnect the oil connector tube from the nozzle line.
  - See Figure 2. Loosen the splined nut from the nozzle line. Loosen the hex head screw securing the escutcheon plate to the burner housing.
  - Place the end of a ruler at the face of the nozzle and, using a straight edge across the head, measure the distance to the face of the head. (A Beckett T500 gauge may also be used.)
  - Slide the nozzle line forward or back until this dimension for **F heads** is 1 1/8" (1 3/8" to the face of the heat shield, if applicable).
  - Tighten the hex head screw to secure the escutcheon plate to the burner chassis. Then tighten the splined nut and attach the oil connector tube.
- Recheck the "Z" dimension periodically when servicing to ensure the escutcheon plate has not been moved. You will need to reset the "Z" dimension if you replace the air tube or nozzle line assembly.

**NOTICE** The Beckett **Z** gauge (part number Z-2000) is available to permit checking the F head "Z" dimension without removing the burner from the appliance.

Table 3 — Dimensions for Figures 2, 3 and 4

Dimension (inches)	For usable length, A (inches):		
	F head	L1 head	V1 head
H (nozzle to head), ± 1/32	N/A	1/4	1/4
L (total tube length)	A + 1/2	A + 1/2	A + 1/2
R (electrode length), ± 1/4	A + 2 1/4	A + 1 1/8	A + 1 1/8
S (adapter to static plate), ± 1/16	2 13/16 (note 1)	1 3/8	1 3/8
Q (nozzle line length)	A + 15/16	A + 3/16	A + 3/16
Z (F head — no heat shield) (F head — with heat shield)	1 1/8 1 3/8	NA NA	NA NA
Z (L1/V1 head — straight shroud) (L1/V1 head — conic shroud)	NA NA	1 3/8 1 3/4	NA 1 3/4

Note 1: 1 3/8 for dimension A less than 3 3/8; 1 5/8 for dimension A between 3 5/8 and 4 1/2

### Check/adjust "Z" dimension - "L1" head

**Figure 3** — "L1" heads (see Table 3 and Figure 2 for dimensions)

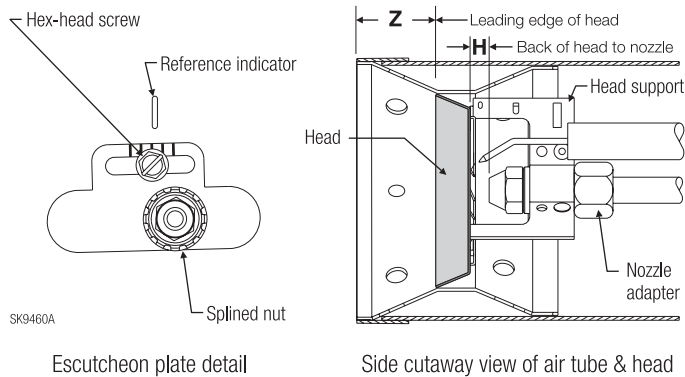

- See Figure 3. The important "Z" dimension is the distance from the leading edge of the head to the end of the air tube. This distance for **L1 heads** is 1 3/8" if the tube has a straight shroud (1 3/4" if the air tube has a conic shroud). The "Z" dimension is factory set for burners shipped with the air tube installed. Even if factory set, verify that the "Z" dimension has not been changed.
- Use the following procedure to adjust the "Z" dimension, if it is not correct:
  - Turn off power to the burner.
  - Disconnect the oil connector tube from the nozzle line.
  - See Figure 3. Loosen the splined nut from the nozzle line. Loosen the hex head screw securing the escutcheon plate to the burner housing.
  - Place the end of a ruler at the leading edge of the head and, using a straight edge across the end of the tube, measure the distance to the end of the air tube. (A Beckett T500 gauge may also be used.)
  - Slide the nozzle line forward or back until this dimension is 1 3/8" for **L1 heads** if the air tube has a straight shroud (1 3/4" if the air tube has a conic shroud).
  - Tighten the hex head screw to secure the escutcheon plate to the burner chassis. Then tighten the splined nut and attach the oil connector tube.
- Recheck the "Z" dimension periodically when servicing to ensure the escutcheon plate has not been moved. You will need to reset the "Z" dimension if you replace the air tube or nozzle line assembly.

### Check/adjust "Z" dimension - "V1" head

**Figure 4** — "V1" heads (see Table 3 and Figure 2 for dimensions)

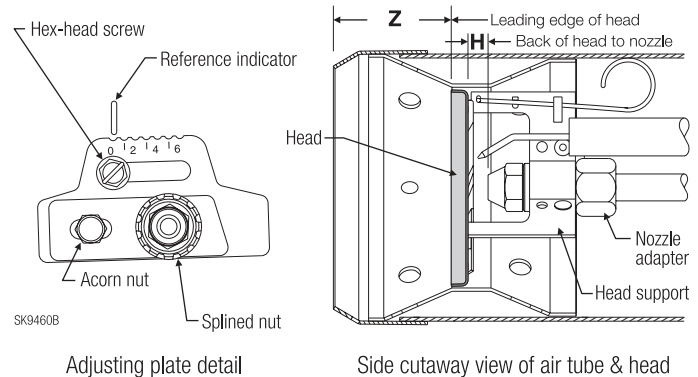

- See Figure 4. The important "Z" dimension is the distance from the leading edge of the head to the end of the air tube. This distance for **V1 heads** is 1 3/4". The "Z" dimension is factory set for burners shipped with the air tube installed. Even if factory set, verify that the "Z" dimension has not been changed.
- Use the following procedure to adjust the "Z" dimension, if it is not correct:
  - Turn off power to the burner.
  - Disconnect the oil connector tube from the nozzle line.
  - See Figure 4. Loosen the splined nut from the nozzle line. Loosen the hex head screw securing the escutcheon plate to the burner housing.
  - Loosen the acorn nut. Move the head adjusting plate until the "0" lines up with the reference indicator on the housing, and retighten the hex head screw. Place the end of a ruler at the leading edge of the head and, using a straight edge across the end of the tube, measure the distance to the end of the air tube. Or use a Beckett T500 gauge. Slide the nozzle line forward or back until this dimension is 1 3/4" for **V1 heads**. Tighten the acorn nut.
  - Tighten the hex head screw to secure the escutcheon plate to the burner chassis. Then tighten the splined nut and attach the oil connector tube.
- Recheck the "Z" dimension periodically when servicing to ensure the escutcheon plate has not been moved. You will need to reset the "Z" dimension if you replace the air tube or nozzle line assembly.

### Set head position adjusting plate ("V1" head only)

- After setting "Z" dimension, loosen head adjusting plate hex head screw and nozzle line splined nut. Move the nozzle line assembly until the burner reference indicator lines up with the head adjusting plate setting number given in Table 3.
- Tighten the hex head screw and splined nut. (DO NOT loosen the acorn nut when setting head position.) Refer to the Beckett *OEM Specification Guide* or manufacturer's instructions for OEM settings.
- The position of the head affects air flow volume and pattern. For most applications, the burner will perform satisfactorily with the air adjustment plate setting of Table 3.
- If combustion results indicate the need for change, adjust the head position adjusting plate forward or back one position at a time to optimize combustion.

**Table 3** — Starting adjusting plate settings with "V1" head

Firing rate (GPH)	Adjusting plate setting	Firing rate (GPH)	Adjusting plate setting
0.75 – 1.00	0	2.00 – 2.25	4
1.00 – 1.50	1	2.25 – 2.50	5
1.50 – 1.75	2	2.50 – 2.75	6
1.75 – 2.00	3		

## Adjust, pipe & wire burner

### Mount burner on appliance

#### Mounting options

- Bolt the burner to the appliance using the factory-mounted flange or an adjustable flange.

#### Mounting dimensions

- When using the Beckett universal adjustable flange, mount the air tube at a 2° downward pitch unless otherwise specified by the appliance manufacturer.
- Verify that the air tube installed on the burner provides the correct insertion depth. See Figure 5.
- The end of the air tube should normally be 1/4" back from the inside wall of the combustion chamber. Never allow the leading edge of the head assembly to extend into the chamber, unless otherwise specified by the heating appliance manufacturer. Carefully measure the insertion depth when using an adjustable flange. Verify the insertion depth when using a welded flange.

Figure 5 — Mounting burner in appliance

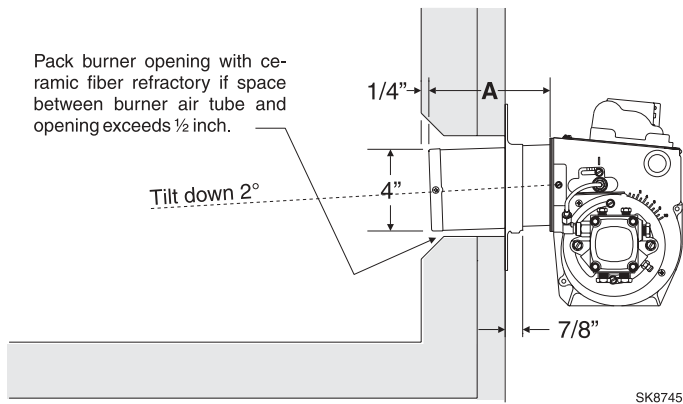

### Connect fuel lines

Carefully follow the fuel unit manufacturer's literature and the latest edition of NFPA 31 for oil supply system specifications. If this information is unavailable, use the following basic guidelines.

**NOTICE** Fuel units with automatic bypass do not require a bypass plug.

**WARNING** The burner fuel unit is shipped without the bypass plug installed. You must install this plug on two-pipe oil systems. **DO NOT** install the plug in the fuel unit if connected to a one-pipe oil system. Failure to comply could cause fuel unit seal failure, oil leakage and potential fire and injury hazard.

#### Fuel supply level with or above burner —

The burner may be equipped with a single-stage fuel unit for these installations. Connect the fuel supply to the burner with a single supply line if you want a one-pipe system (making sure the bypass plug is NOT installed in the fuel unit.) Manual venting of the fuel unit is required on initial start-up. If connecting a two-pipe fuel supply, install the fuel unit bypass plug.

**WARNING** The oil supply inlet pressure to the fuel unit cannot exceed 3 psi. Install a pressure-limiting device in accordance with NFPA 31.

#### Fuel supply below the level of the burner —

When the fuel supply is below the level of the burner, a two-pipe fuel supply system is required. Depending on the fuel line diameter and horizontal and vertical length, the installation may also require a two-stage pump. Consult the fuel unit manufacturer's literature for lift and vacuum capability.

### Connect fuel lines (continued)

#### Fuel line installation —

- Continuous lengths of heavy wall copper tubing are recommended. **Always use flare fittings. Never use compression fittings.**
- Always install fittings in accessible locations. Fuel lines should not run against the appliance or the ceiling joists (to avoid vibration noise).

**WARNING** Never use Teflon tape on any fuel fitting. Tape fragments can lodge in fuel line components and fuel unit, damaging the equipment and preventing proper operation.

#### Fuel line valve and filter —

- Install two high quality **shutoff valves** in accessible locations on the oil supply line. Locate one close to the tank and the other close to the burner, upstream of the filter.

**NOTICE** Some states require these valves to be fusible-handle design for protection in the event of fire. We recommend this as good industry practice for all installations.

- Install a generous capacity **filter** inside the building between the fuel tank shutoff valve and the burner, locating both the filter and the valve close to the burner for ease of servicing. Filter should be rated for 50 microns or less.

### Wire burner

#### Burner packaged with appliance

- Refer to appliance manufacturer's wiring diagram for electrical connections.

#### Burner applied at jobsite

- Refer to Figures 6 and 7, page 9, for typical burner wiring, showing cad cell primary controls. Burner wiring may vary, depending on primary control actually used. The oil valve shown in Figures 6 and 7 may be an optional feature.

**NOTICE** All wiring must be in accordance with the latest revision of National Electric Code NFPA 70 and local codes and regulations.

**WARNING** The wiring diagrams in this manual are for *general reference only*, and apply only to burners equipped with R8184G or R7184 primary controls. For other controls, refer to the control manufacturer's literature or the diagrams supplied with the appliance. Failure to apply correct wiring could result in severe personal injury, death or substantial property damage.

**NOTICE** The **R7184** primary control with valve-on delay (*prepurge*) and burner motor-off delay (*postpurge*), shown in Figure 7, page 9, requires a constant 120 VAC power source supplied to the **BLACK** wire on the control. The **RED** wire goes to the appliance limit circuit. Please note that other control manufacturers may use different wire colors for power and limit connections.

#### Covered burners

The mounting plate is not a conduit connection point. Pass conduit and attached connector through the opening in the mounting plate (see illustration at right) and attach it directly to the burner-mounted 4x4 electrical box.

If attaching a burner cover to a previously installed burner, attach the mounting plate and then slide the conduit into the "J" shaped conduit slot.

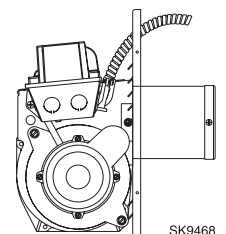



## Adjust, pipe & wire burner

**Figure 6** — Typical wiring, R8184G or equivalent primary control

**DANGER** Electrical shock hazard. Disconnect power before servicing.

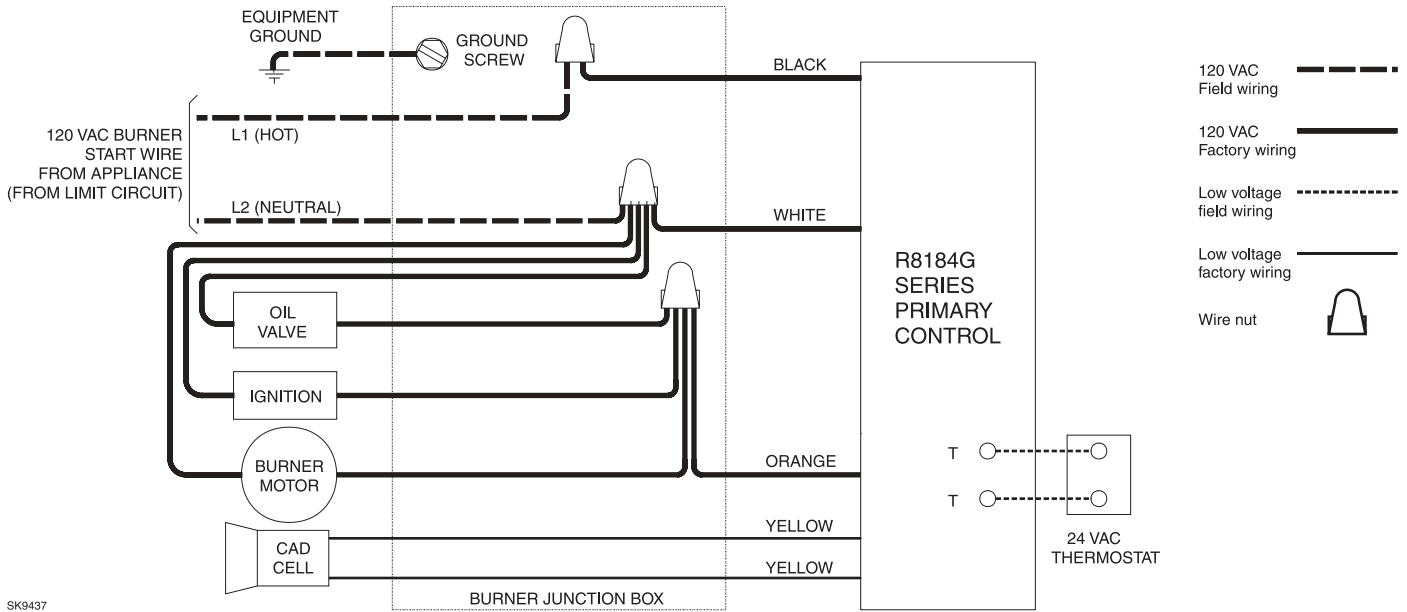

SK9437

**Figure 7** — Typical wiring, R7184 primary control (R7184P shown)

**DANGER** Electrical shock hazard. Disconnect power before servicing.

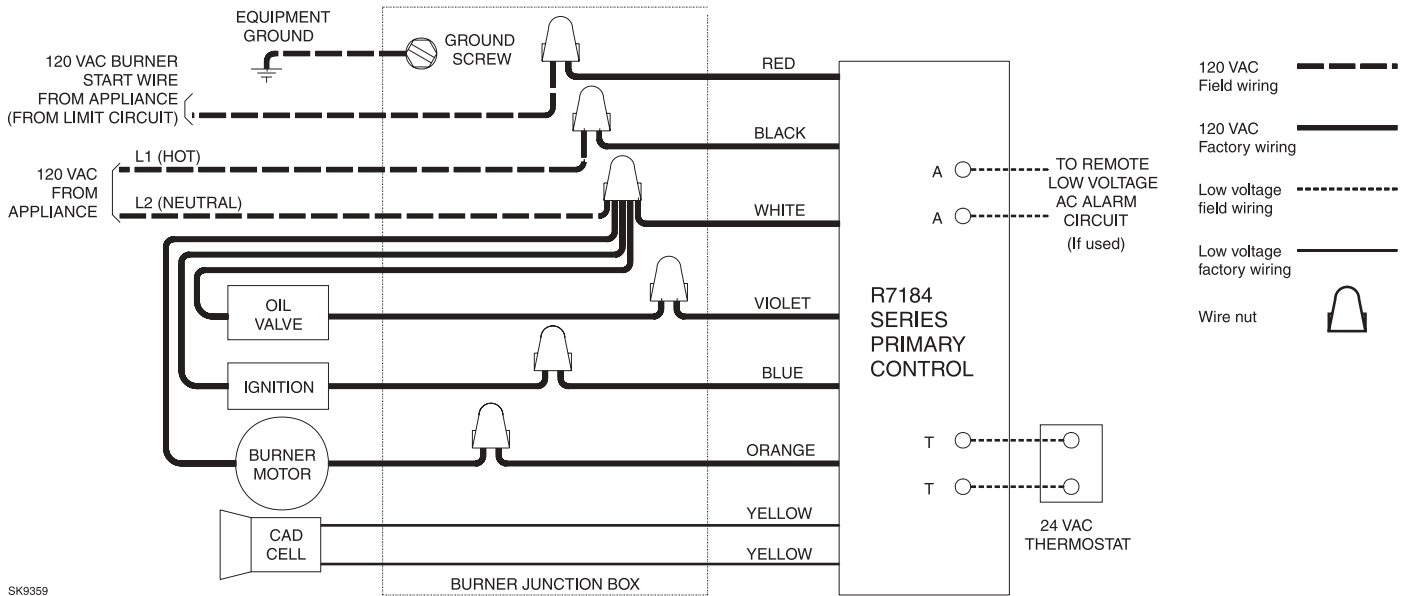

SK9359

**Table 5** — R7184 primary control features

Feature	R7184A	R7184B	R7184P
Interrupted ignition	YES	YES	YES
Limited reset, limited recycle	YES	YES	YES
Diagnostic LED, cad cell indicator	YES	YES	YES
Valve-on delay		YES	YES
Burner motor-off delay			YES
Alarm contacts			Optional

## Startup & adjust burner

### Startup burner/set combustion

**WARNING** Do not attempt to start the burner when excess fuel or vapor has accumulated in the appliance. Starting the burner under these conditions could result in a puffback of hot combustion gases, high smoke levels, or otherwise hazardous operation.

1. Open the shutoff valves in the oil supply line to the burner.
2. Close air band and partially open air shutter. This is an initial air setting for the pump venting procedure only. Additional adjustments must be made with instruments.
3. Set the thermostat substantially above room temperature.
4. Close the line voltage switch to start the burner. If the burner does not start immediately you may have to reset the safety switch of the burner primary control.
5. **Vent air from fuel unit** as soon as burner motor starts rotating.

To vent the fuel unit, attach a clear plastic hose over the vent plug. Loosen the plug and catch the oil in an empty container. Tighten the plug when all air has been purged from the oil supply system.

- If the burner locks out on safety during venting, reset the safety switch and complete the venting procedure. Note — Electronic safety switches can be reset immediately; others may require a three- to five-minute wait.
  - If burner stops after flame is established, additional venting is probably required. Repeat the venting procedure until the pump is primed and a flame is established when the vent plug is closed.
  - For R7184 primary controls, see *Technician's Quick Reference Guide*, Beckett part number 61351, for special pump priming sequence.
  - Prepare for combustion tests by drilling a 1/4" sampling hole in the flue pipe between the appliance and the barometric draft regulator.
6. **Initial air adjustment** — Using a smoke tester, adjust the air shutter (and air band, if necessary) to obtain a clean flame. Now the additional combustion tests with instruments can be made.

### Set combustion with instruments

**WARNING** The combustion must be adjusted using test instruments. Failure to do so could result in burner or appliance failure, causing potential severe personal injury, death or substantial property damage.

1. Let burner run for approximately 5 to 10 minutes.
2. Set the over-fire or stack draft to level specified by appliance manufacturer (usually -0.01 to -0.02 inches w.c. over-fire for natural draft applications).
3. Follow these four steps to properly adjust the burner:
  - Step 1:** Adjust air until a trace smoke level is achieved.
  - Step 2:** At the trace of smoke level, measure the CO<sub>2</sub> (or O<sub>2</sub>). This is the vital reference point for further adjustments.
    - Example: 13.5% CO<sub>2</sub> (2.6% O<sub>2</sub>).
  - Step 3:** Increase the air to reduce CO<sub>2</sub> by 1 to 2 percentage points. (O<sub>2</sub> will be increased by approximately 1.4 to 2.7 percentage points.)
    - Example: Reduce CO<sub>2</sub> from 13.5% to 11.5%. (O<sub>2</sub> — 2.6% to 5.3%).
  - Step 4:** Recheck smoke level. It should be zero.
    - This procedure provides a margin of reserve air to accommodate variable conditions.
    - If the draft level has to be changed, recheck the smoke and CO<sub>2</sub> levels. Adjust the burner air if necessary.
4. Once combustion is set, tighten all fasteners on air band, air shutter and head adjusting plate or escutcheon plate.
5. Burner equipped with cover — Reinstall cover and repeat steps 2 and 4 above. If CO<sub>2</sub> increases (O<sub>2</sub> decreases), remove the cover and adjust the air setting so the CO<sub>2</sub> (O<sub>2</sub>) with cover on meets the requirements of step 3.
6. Start and stop the burner several times to ensure satisfactory operation. Test the primary control and all other appliance safety controls to verify that they function according to the manufacturer's specifications.

## Service & maintain burner

### Perform annual maintenance

**WARNING** This equipment must be serviced only by a qualified service agency. The appropriate test instruments must be used. Failure to do so could result in burner or appliance failure, causing potential severe personal injury, death or substantial property damage.

- Replace the oil supply line filter. The line filter cartridge must be replaced to avoid contamination of the fuel unit and nozzle.
- Inspect the oil supply system. All fittings should be leak-tight. The supply lines should be free of water, sludge and other restrictions.
- Remove and clean the pump strainer if applicable.
- Replace the nozzle with an equivalent nozzle.
- Clean and inspect the electrodes for damage, replacing any that are cracked or chipped.
- Check electrode tip settings. Replace electrodes if tips are rounded.
- Inspect the igniter spring contacts.
- Clean the cad cell grid surface, if necessary.
- Make sure low firing rate baffle is in place if required for the burner application. Omitting the baffle can result in unacceptable burner combustion.
- Inspect all gaskets. Replace any that are damaged or would fail to seal adequately.
- Clean the blower wheel, air inlet, air guide, retention head and static plate of any lint or foreign material.
- If motor is not permanently lubricated, oil motor with a few drops of SAE 20 nondetergent oil at each oil hole. DO NOT over oil motor. Excessive oiling can cause motor failure.
- Check motor current. The Amp draw should not exceed the nameplate rating by more than 10%.
- Check all wiring for secure connections or insulation breaks.
- Check the pump pressure and cutoff function.
- Check primary control safety lockout timing.
- Check ignition system for proper operation.
- Inspect the vent system and chimney for soot accumulation or other restriction.
- Clean the appliance thoroughly according to the manufacturer's recommendations.
- Check the burner performance. Refer to the section "Set combustion with instruments."

It is good practice to make a record of the service performed and the combustion test results.

### To replace blower wheel:

1. Turn off all power to the burner before servicing.
2. Disconnect the wires to the burner motor.
3. Remove the bolts securing the blower motor to the housing.
4. Remove the blower motor and wheel.
5. Remove the existing wheel.
6. As shown at right, slide the new blower wheel onto the shaft.
  - Place a .030" (1/32" ± 1/64") feeler gauge on the motor as shown.
  - Slide blower wheel toward motor until it contacts feeler gauge.
  - Rotate the wheel until the set screw is centered on the flat of the motor shaft.
  - Tighten the set screw to secure the wheel.
7. DO NOT use a motor that has endshield openings outside the blower wheel circumference represented by the dashed line.
8. Install the motor on the burner housing. Tighten screws. Reconnect motor wires.
9. Restore power, start the burner and perform combustion tests. Refer to "Set combustion with instruments."

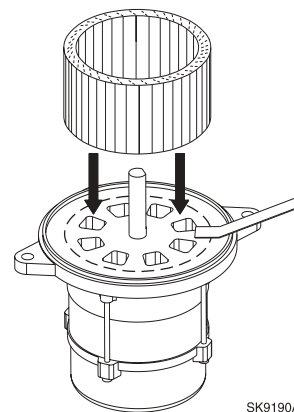

SK9190A

## Service & maintain burner

### Replacement parts

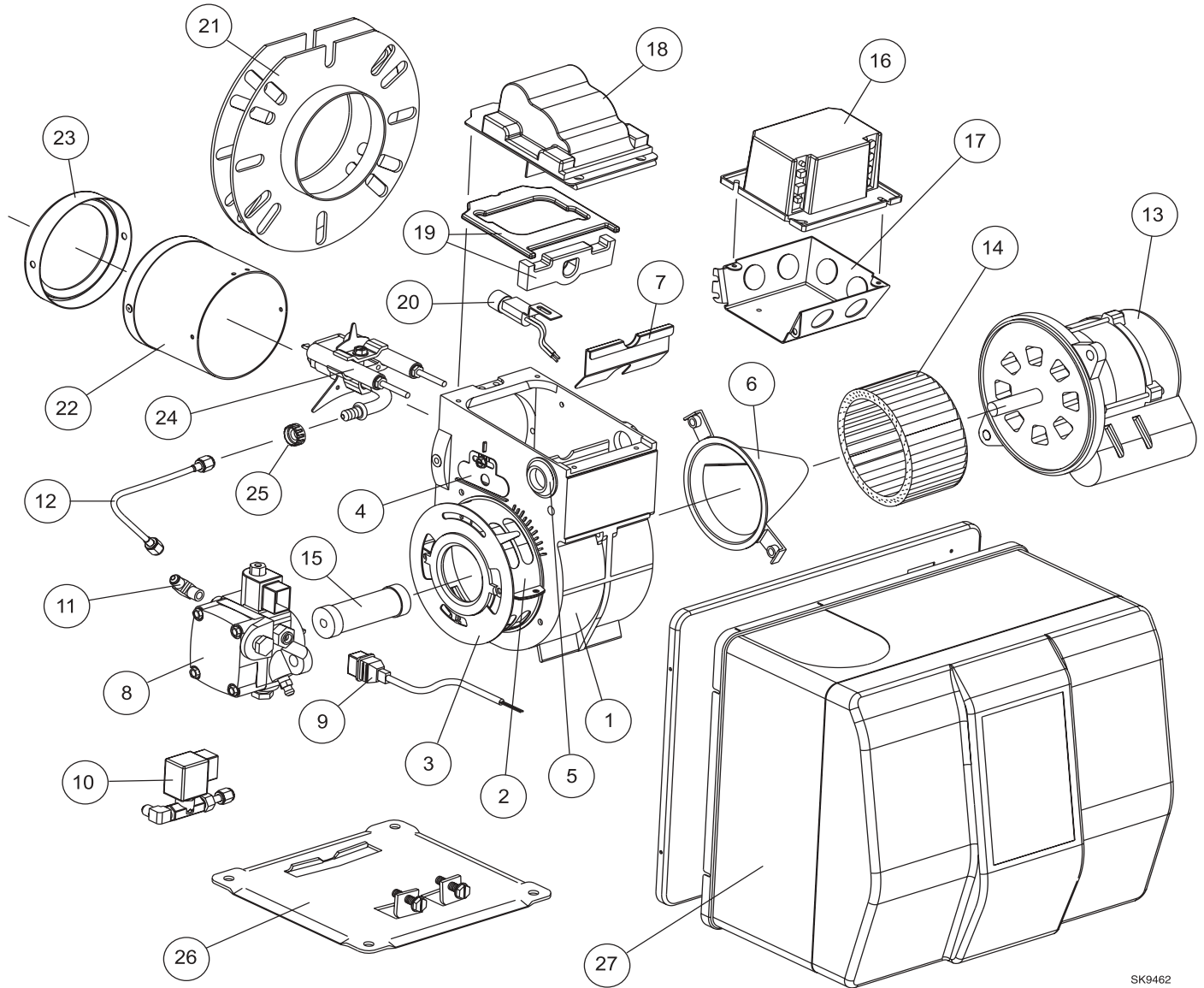

SK9462

Item	Description	Part Number
1	Burner housing assembly	5877
2	Air band assembly — 8 slot	5151501
(note 1)	Screw 10-24 x 1/2"	4198
	Nut 10-24 square	4150
3	Air shutter — 4 slot	3709
(note 1)	Screws 10-24 x 5/16"	4292
4	Escutcheon plate (F & L1 heads)	3493
(note 1)	Head adjusting plate assembly (V1 head)	5941
	Screw 10-32 x 5/16"	4292
5	Hole plug	2139
(note 1)		
6	Air guide (note 2)	31231U
(note 1)		
7	Low firing rate baffle — silver (note 3)	5880
(note 1)		
8	Pump	A2VA7116 ( <i>Suntec</i> ) 2460U A2EA6520N621L ( <i>CleanCut</i> ) 21844U BFPH071N1161 ( <i>Danfoss</i> ) 21391U
	Mounting screws 1/4-20 x 7/8"	4189
9	Valve cordset (for 21844pump)	21807
10	Solenoid valve kit (non-delay)	2182602U
11	Pump elbow	2256
12	Connector tube assembly, 8"	5394
13	Motor PSC	21805U
	Mounting screws 1/4-20 x 7/8"	4189

Item	Description	Part Number
14	Blower wheel (use only RWB replacement)	2999U
15	Coupling	2454
16	Primary control	R7184A — interrupted ignition 7455U R7184B — valve-on delay 7456U R7184P — valve-on / motor-off delay 7457U R7184P with alarm contacts 7458U
17	Electrical box	5770
18	Igniter	51771U
19	Igniter gasket kit	51304
20	Cad cell detector	7006U
21	Flange — universal, adjustable, incl. gasket	5432
	Gasket only	3616
22	Air tube combination — see Table 1, page 2	Specify
23	Heat shield kit — ceramic or fiber	Specify
24	Electrode kit	F head air tubes up to 9" 5780 M head air tubes up to 9" 5940
25	Splined nut	3666
26	Pedestal kit	5685
27	Cover	51814U

Note 1 These items are included in the 5877 burner housing assembly.

Note 2 Factory installed. **Please do not remove from burner!**

Note 3 See "Prepare Burner", page 5, for low firing rate baffle usage

## Service & maintain burner

### Owner's information

**WARNING** This burner must be installed, adjusted and started only by a **qualified service agency** — an individual or agency, licensed and experienced with all codes and ordinances, who is responsible for the installation and adjustment of the equipment.

- Have your equipment **inspected and adjusted at least annually** by your **qualified service agency** to assure continued proper operation.
- Installation and adjustment of the burner requires technical knowledge and the use of combustion test instruments. **Do not tamper** with the unit or controls. Call your **qualified service agency**.
- **Incorrect operation of the burner could result in severe personal injury, death or substantial property damage.**

The following could result in fire hazard, severe personal injury, death or substantial property damage. Read carefully.

- **Never** attempt to **use gasoline** in your heating appliance.
- **Never store gasoline or combustible materials** near the burner or appliance.
- **Never** attempt to burn **garbage or refuse** in your appliance.
- **Never** attempt to **light the burner/appliance** by throwing burning material into the appliance.
- **Never** attempt to use **crankcase or waste oil** or material other than the approved fuel oils in this burner.
- **Never** restrict the air inlet openings to the burner or the combustion air ventilation openings in the room.

The OilHeat Manufacturers' Association supports the use of low sulfur fuels as defined by ASTM D396, Grades Number 1 Low Sulfur and Number 2 Low Sulfur, as the preferred heating fuel for the following reasons:

- Low sulfur fuels reduce deposits on heat exchanger surfaces, extending the service interval between cleanings.
- The reduced deposits increase the efficiency of the appliance.
- Low sulfur fuels reduce particulate emissions.
- Low sulfur fuels reduce oxides of nitrogen emissions.

### Owner service and maintenance

Properly installed and maintained, your **AFG** burner will provide years of efficient, trouble-free operation. Please take care of your equipment by following the warnings provided and by doing the following (notify your qualified service agency if you find anything wrong):

#### Annually (minimum)

- Have your burner/heating appliance serviced at least annually by your qualified service agency as noted above.

#### Daily

- Check the room in which your burner/appliance is installed. Make sure:
  - air ventilation openings are clean and unobstructed
  - nothing is blocking the burner inlet air openings
  - no combustible materials are stored near the heating appliance
  - there are no signs of oil or water leakage around the burner or appliance.

#### Weekly

- Check your oil tank level. Always keep your oil tank full, especially during the summer, in order to prevent condensation of moisture on the inside surface of the tank.

### Warranty

Beckett warrants its equipment specifically to those who have purchased it for resale, including your qualified service agency (dealer). In the event of any problems with your equipment or its installation, you should contact your dealer for assistance.

---

## R. W. BECKETT CORPORATION

U.S.A.: P. O. Box 1289 • Elyria, Ohio 44036

Canada: R. W. Beckett Canada, Ltd. • Unit #3, 430 Laird Road • Guelph, Ontario, N1G 3X7

Subject to change without notice. Printed in U.S.A.  
Copyright © by York International Corp. 2002. All rights reserved.

035-18783-001 Rev. A (0803)  
Supersedes: Nothing

**Unitary  
Products  
Group**

**5005  
York  
Drive**

**Norman  
OK  
73069**

